

MODEL 200

REAR LOAD



- **Kicker Bar "Friendly"**
Slim design allows installation on most rear load trucks that utilize a kick/container bar for emptying commercial containers.
- **Eliminates Bottom Bar Cart Damage**
Patented spring bottom bar latching system virtually eliminates bottom bar damage by providing shock absorption during dump cycle and also ensures above ground release.
- **Self-Aligning Ball Bushings**
Made of hardened steel, shock and corrosion resistant, and require very low lubrication maintenance.
- **Cushioned Hydraulic Cylinder**
Hydraulic cylinder provides a smooth lifting action in both up & down directions which helps prevent cart damage.
- **Fully Adjustable**
Mounting plate, top bar holder, and bottom latch assembly are fully adjustable to help ease the installation on most rear load trucks.
- **No Sweep Blade Interference**
Correctly mounted Cart Lifter in dump position will not make contact with packer blade, preventing any possibility of packed lifter damage.

Diamondback 3rd Man Tippers are engineered with fewer moving parts for longer life, easier maintenance, and to save you money on parts inventory.

Simple is Better.



888-313-1424 • www.diamondbackproducts.com



CLEARANCE AND DIMENSIONS

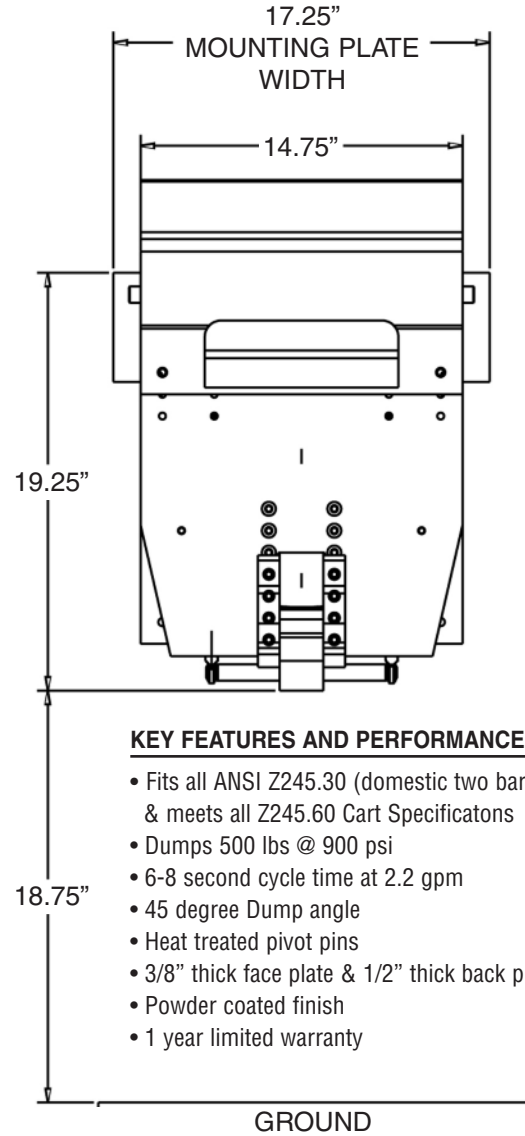
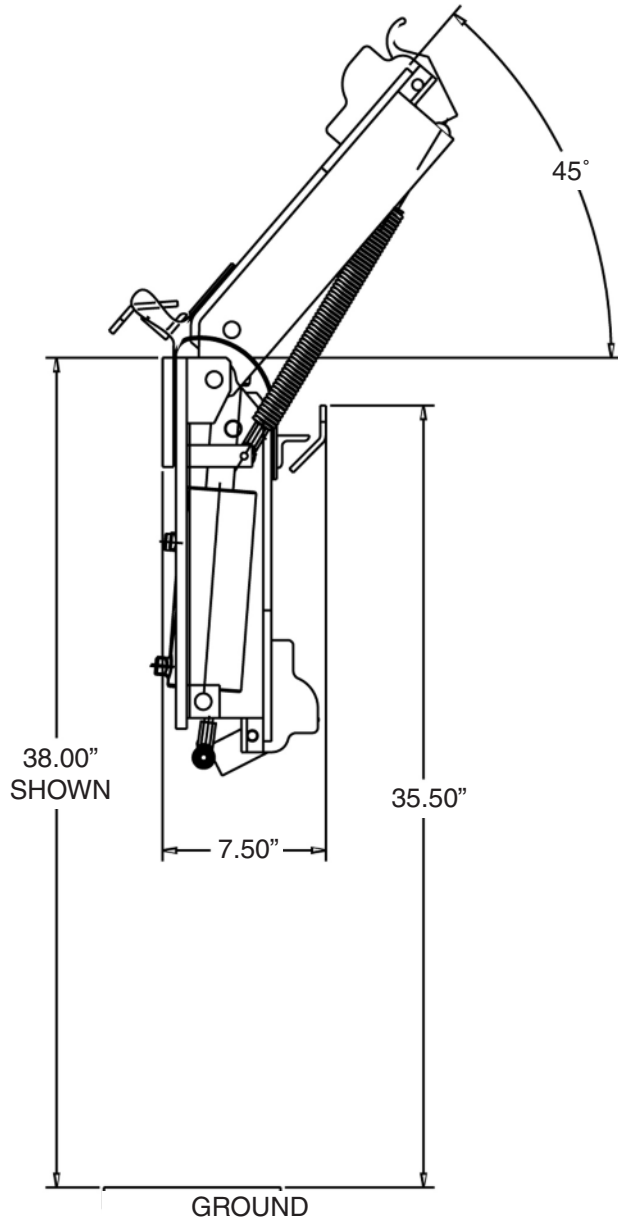

KEY FEATURES AND PERFORMANCE SPECS

- Fits all ANSI Z245.30 (domestic two bar style) Carts & meets all Z245.60 Cart Specifications
- Dumps 500 lbs @ 900 psi
- 6-8 second cycle time at 2.2 gpm
- 45 degree Dump angle
- Heat treated pivot pins
- 3/8" thick face plate & 1/2" thick back plate
- Powder coated finish
- 1 year limited warranty